

J. C. & H. J. TERRY.
Button-Lathe.

No. 222,962.

Patented Dec. 23, 1879.

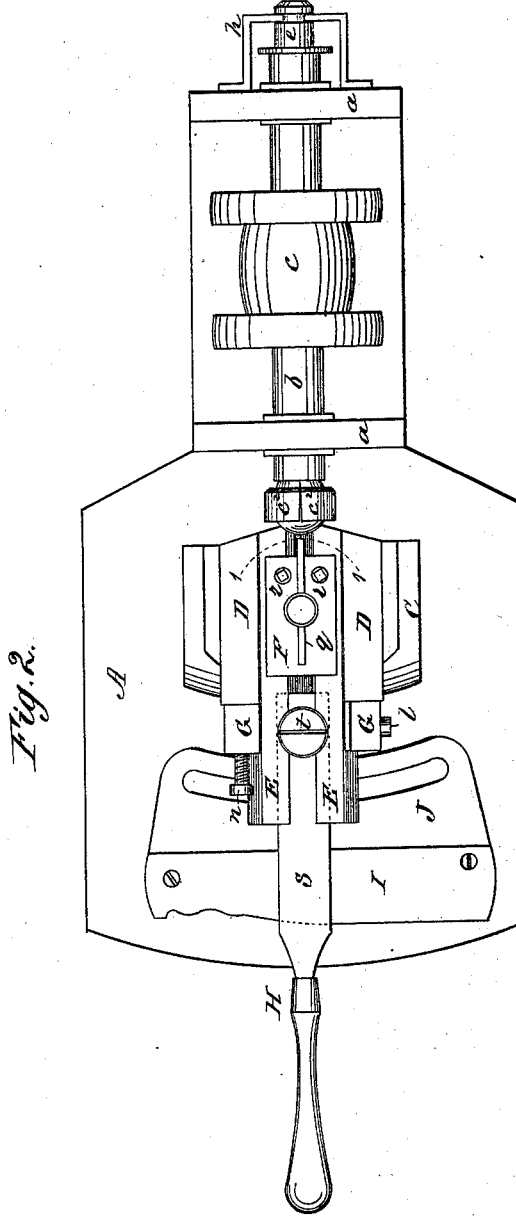
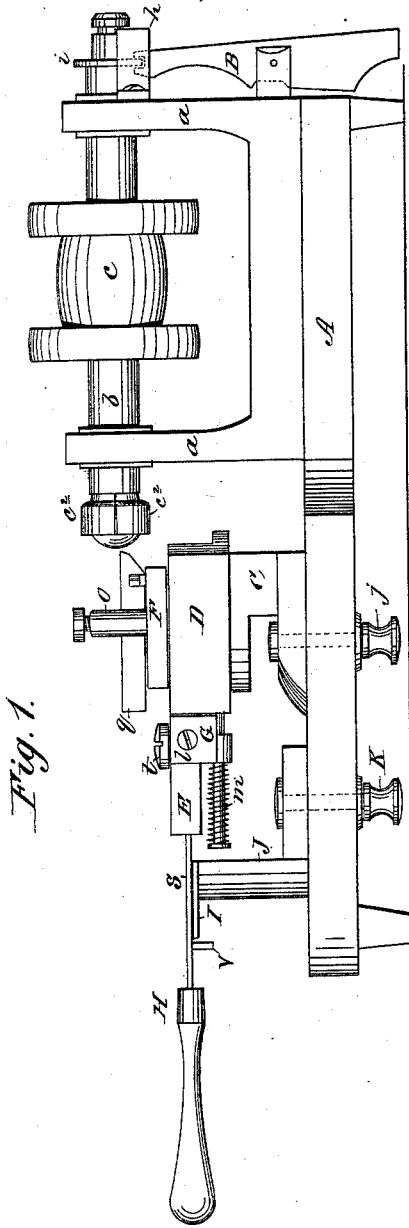

WITNESSES:

W. W. Hollingsworth
Edw. U. Byrn

INVENTOR:

J. C. Terry
H. J. Terry
BY *Wm. L. Terry*
ATTORNEYS.

J. C. & H. J. TERRY.
Button-Lathe.

No. 222,962.

Patented Dec. 23, 1879.

Fig. 4.

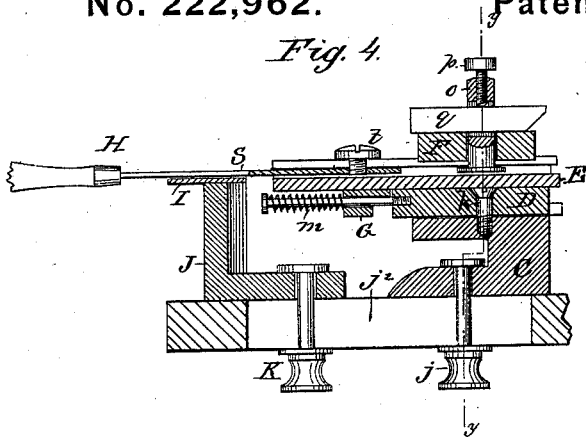

Fig. 5.

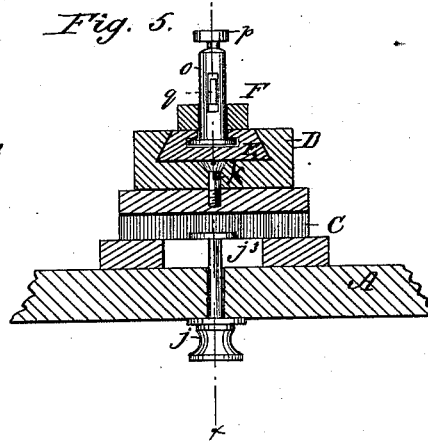

Fig. 3.

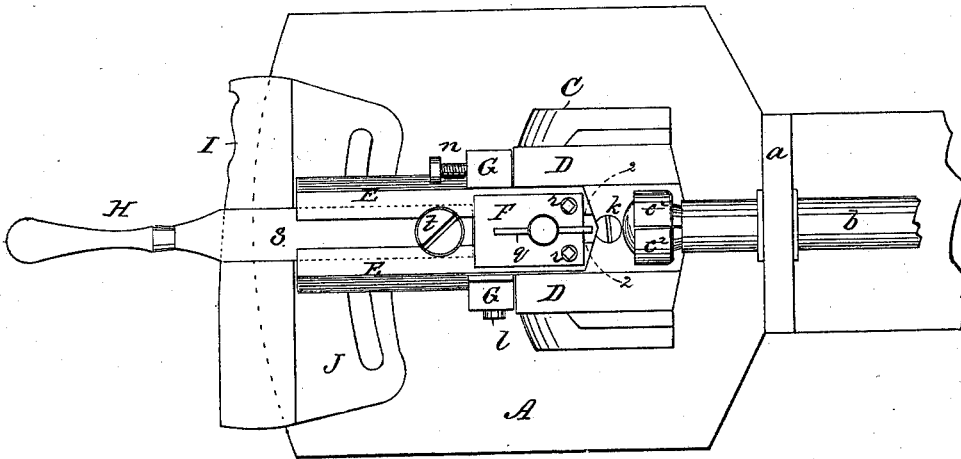
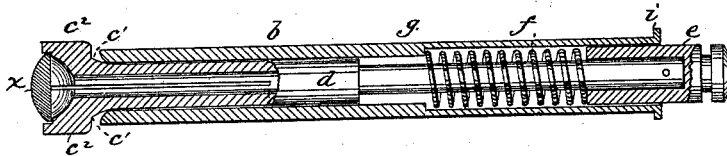

Fig. 6.



WITNESSES:

W. W. Hollingsworth
Edw. W. Byron

INVENTOR:

J. C. Terry
H. J. Terry
 BY *Wm. C. Terry*
 ATTORNEYS.

UNITED STATES PATENT OFFICE.

JABEZ C. TERRY AND HERBERT J. TERRY, OF SPRINGFIELD, MASS.

IMPROVEMENT IN BUTTON-LATHES.

Specification forming part of Letters Patent No. 222,962, dated December 23, 1879; application filed October 25, 1879.

To all whom it may concern:

Be it known that we, JABEZ C. TERRY and HERBERT J. TERRY, of Springfield, in the county of Hampden and State of Massachusetts, have invented a new and Improved Button-Lathe; and we do hereby declare that the following is a full, clear, and exact description of the same, reference being had to the accompanying drawings, forming part of this specification, in which—

Figure 1 is a side elevation; Fig. 2, a plan view; Fig. 3, a partial plan view, showing another position of the cutting-tool. Fig. 4 is a vertical longitudinal section of the tool-supporting device, taken on line *x x* of Fig. 5. Fig. 5 is a vertical transverse section of the same, taken on line *y y* of Fig. 4. Fig. 6 is a longitudinal section of the hollow revolving arbor.

Our invention relates to a novel construction of machine for turning buttons from wood, ivory, mother-of-pearl, horn, or other substance.

It is designed for turning buttons into finished shape from blanks previously prepared; and instead of operating upon the principle of a cutter formed to suit the pattern of button, it employs a single cutting-tool, which, by a variety of adjustments, that may be effected either by hand or automatically, permits the button to be turned and finished according to any desired pattern.

The construction of this machine, though not designed for great rapidity of work, permits an infinite number of variations in the contour of the button, and while allowing any desired change of shape without substitution of special cutters, it also gives a very smoothly-cut and finely-finished face.

By reason of the capabilities of the machine it may be termed the "Universal Button-Lathe."

Its chief features consist, first, in the peculiar means for holding and rotating the button-blank by gripping it peripherally, and, secondly, in the several adjustments of the tool-support for varying the contour of the button.

Tributary to these general features are others of special construction, all of which will be hereinafter more fully described.

In the drawings, A represents a frame, upon

which the working parts of the machine are mounted, which frame may be of any approved construction adapted to properly sustain the working parts in convenient position.

At one end of the frame are arranged standards *a a*, in bearings in which there revolves the tubular arbor *b*, to which a spool or pulley, *c*, is keyed or otherwise rigidly attached, which pulley is connected through a belt with a drive-pulley of such relative size as will give the necessary speed to the arbor.

For gripping the button-blank we employ within the hollow arbor a set of slitted spring gripping-jaws, *c' c'*, which are united in a solid stem, *d*, (see Fig. 6,) which, at the rear end, is provided with a thimble, *e*. This thimble forms a shoulder at its edge inside the tubular arbor, against which bears a spiral spring, *f*, wound around the stem *d*, while the forward edge of the spring bears against a shoulder, *g*, formed on the inner side of the tubular arbor. This spring *f* being compressed between these two bearing-points, its tension has a tendency to throw the arbor over the inclined surface *c'* of the jaws *c'*, so as to compress them and cause them to gripe the button-blank, which is shown at *x*. In arranging these parts for adjustment the rear end of the thimble *e* is grooved circularly, and a rigid yoke or bracket, *h*, Fig. 2, is firmly fixed to the framework, and made to enter the groove in said thimble, so that the thimble and attached jaws can rotate, but cannot have a longitudinal movement. The tubular arbor, on the other hand, is provided at its back end with a flange, *i*, which is grasped by the forked upper end of lever B, Fig. 1, which lever allows the arbor to revolve freely, but provides a means for throwing the arbor back against the tension of the spring within, to open the jaws whenever the button-blank is to be inserted or removed. For imparting this movement to the lever B a treadle or other suitable appliance is to be brought into requisition.

Ordinarily the simple tension or friction between the hollow arbor and the gripping-jaws and stem, caused by the interposed spring, will be sufficient to transmit the rotary action of the arbor to the jaws. In fact, this is a desirable construction, since, if the cutting-tool strikes on the jaws, the jaws will not be dis-

figured, but will stop, while the arbor will continue to revolve against the tension of the spring. If a more positive connection is required, the stem of the jaws and the arbor may be connected by a slot and a pin, so that they can revolve positively together, but have a free movement, the one upon the other.

Just in front of the devices for gripping the button-blank are arranged the adjusting devices for the cutting-tool, which may be described as follows: A base-block, C, is secured upon the platform of the frame by a clamping-bolt, *j*, so as to be adjusted longitudinally with the arbor or laterally thereto. The longitudinal adjustment is effected by making the hole through the platform, through which bolt *j* passes, in the form of an elongated slot, *j*², Fig. 4, in a line with the axis of the arbor, while the lateral adjustment is effected by making the hole in the block C, through which the bolt *j* passes, in the form of an elongated slot, *j*³, Fig. 5, at right angles to the first. This allows the main supporting-block to be fixed in any desired position on the platform to suit the diameter or thickness of the button to be turned. Upon the flat upper surface of the block C we mount the frame D, which is connected to the subjacent block by a vertical pivot-bolt, *k*, Figs. 3, 4, 5, which permits the frame D to be swung horizontally, to traverse the semi-diameter of the blank, as is necessary in the act of turning every blank. Inside of the horizontally-swinging frame D is arranged the dovetail slide E, which itself is undercut in parallel direction to receive the tool-holder proper, F. This dovetail slide has also a movement for every act of turning a button, and its function is to recede and give the necessary figure to the face of the button. For giving this slide E its adjustment to or from the button-blank in proportion to the thickness of the same, it is connected to the horizontally-swinging frame D by the clamping-block G and set-screw *l*. To make the pressure of the tool on the blank, however, yielding, the clamp-block, which is rigidly but adjustably fixed to the slide E, is not rigid with the frame D, but is connected with the same through the tension of the spiral spring *m*, Figs. 1 and 4, the said block pressing against one end of the spring, which is carried on a rearwardly-projecting stem from the horizontally-swinging frame D.

The object of this construction is to hold the tool into more certain and uniform contact with the blank, whether the tool be operated by hand or automatically. After the adjustment of the dovetail slide E in clamp-block G is obtained the tension of the spring which throws the said dovetail slide forward may be varied by means of set-screw *n*, Figs. 2 and 3, which throws the clamping-block away from the horizontally-swinging frame and compresses the spring. This set-screw *n* also gives a back-and-forth adjustment of the tool-holder and its carrying-slide, and has value also in adjusting the pattern, as hereinafter described.

The tool-holder F consists of a block rest-

ing upon and guided on the top of the dovetail slide E, and a slotted standard, *o*, which has a foot below, which engages with the undercut edges of said slide E, (see Figs. 4 and 5,) and a set-screw, *p*, at the top, so arranged that when the tool *q* is clamped in the slot of the standard by set-screw *p* the reacting strain causes the foot of the standard to clamp the slide E and fix the position of the tool-holder F with respect to said slide. Set-screws *r r*, Figs. 2 and 3, serve to raise or lower the tool-holder as may be required. These separate adjustments of the tool-holder F permit its position to be changed without the necessity of changing the adjustment of the supporting parts.

For swinging the tool-holder, slide, and horizontal frame from right to left, a handle, H, is employed, when the machine is to be operated by hand, and said handle is connected to the slide E by a tongue, *s*, which enters the undercut groove of said slide, and is adjustably fixed thereto by a binding-screw, *t*.

The machine, as so far described, is, in the hands of a skilled workman, capable of successful use—*i. e.*, for all plain forms of button, the form being known to the workman, a skillful manipulation of the tool-holder will be sufficient to give the proper shape to the buttons.

To adapt the machine to use in the hands of unskilled persons, however, we attach a pattern or form, which, being first wrought out to produce a given shape of button, will mechanically control the movement of the hand-lever H, and cause each button to be turned in accordance with that form.

I is the pattern or form which is in the nature of a detachable steel plate fixed to a support, J, which latter is made adjustable right and left and backward and forward by a clamp-bolt, K, passing through a slot in the platform and another at right angles in the pattern-support J. The rear edge of the pattern is wrought into the desired shape, and a stud or pin, *v*, Fig. 1, projects downwardly from the lever-handle, and binds against the pattern. Now, when the handle is thrown to one side the lateral movement causes the tool to traverse the semi-diameter of the button-blank to be turned, while the curve of the pattern causes the dovetail slide to advance or retreat against the tension of its spring, to cause the tool to have a corresponding movement, to form the various configurations on the face of the button.

In fitting the pin of the handle H to the pattern, the set-screw *n* is first advanced until block G is slightly drawn back against the tension of its spring and away from the frame D. The pin of the handle H is then fitted to the pattern, and set-screw *n* then released. This causes the spring to draw the pin snug up to the pattern, and avoids any looseness which might interfere with the correct representation of the pattern.

In operating with the machine the various

carrying parts are adjusted to suit the circumstances of the case, the blank inserted, and the tool then adjusted to the periphery of the same, and then turned either by hand or automatic mechanism to the center. The result is, that the rapid rotation of the blank causes it to be exactly and smoothly turned to the desired shape. The partially-formed button is then dropped by the loosening of the jaws, and its dislodgment facilitated, if desired, by an extractor or discharging-spring fixed between the jaws. Another blank is then inserted and the first action repeated.

With respect to the spring-seated character of the tool-carrying devices, we would state that this is an important feature of our invention, and we do not limit ourselves to the precise construction of parts shown for accomplishing this result, since we may make the advancing slide which carries the tool-holder spring-seated by any suitable means.

The adjustment of the tool-carrying slide from one side to the other of the pivot upon which the frame swings horizontally is also a very desirable feature, since it permits the tool to describe, from the swing of the frame, either a curve which gives concave or convex cut, without other adjustment than the simple change of position of the tool from the front to the back of the pivot-bolt. Thus, if the tool be in front of the pivot-bolt, or between the pivot-bolt and the blank, as shown in Fig. 2, the horizontal swing of the frame D causes the tool to describe the arc 1 1, cutting a concave button, while if the tool be in the rear of the pivot-bolt, as in Fig. 3, the same swing of the frame D causes the tool to describe the arc 2 2, which gives a convex cut to the blank.

Having thus described our invention, what we claim as new is—

1. The combination of the sliding hollow arbor *b*, carrying driving-pulley, the gripping-jaws connected with stem and thimble within said arbor, and having a swiveling connection outside of the same to prevent longitudinal movement, a spiral spring interposed between the arbor and stem, and a lever, *B*, having a loose rotary connection with the arbor for adjusting the same longitudinally, as described.

2. The tool-holding devices consisting of the slide *E*, having an undercut groove, the block *F*, the slotted standard *o*, having a foot below contained within the undercut groove, and a set-screw, *p*, at the top, adapted to bind against the tool in the slotted standard and cause the foot of the standard to react and clamp the supporting-slide, as set forth.

3. The horizontally-swinging frame *D* and the gage-block *G*, connected with the frame *D*, for retrogressive movement through a spring, and clamped adjustably upon the slide carrying the tool-holder, combined as and for the purpose described.

4. The horizontally-swinging frame *D*, having rearwardly-projecting stem, the gage-block *G*, sliding on said stem and backed by a spring, *m*, thereon, and the slide carrying the tool-holder, clamped adjustably by the screws of the gage-blocks, all combined as shown and described.

5. The combination, with the gage-block *G*, clamped to the tool-slide *E*, of the carrying-frame *D*, a spring for holding the gage-block forward against the frame *D*, and the adjusting-screw *n*, for projecting the gage-block from the said frame and adjusting the tension of the spring, as described.

6. The combination of slide *E*, having a longitudinal undercut groove, the tool-holder clamped by means of its foot in said groove, and the handle *H*, having tongue *s* also fitted in said groove, and secured adjustably therein by screw *t*, substantially as described.

7. The combination of the block *C*, made adjustable in slots at right angles by bolt *j*, the horizontally-swinging frame *D*, carrying tool-holder slide *E*, the gage-block *G*, clamped to slide *E*, and connected to frame *D* for retrogressive movement through a spring, the handle and tongue *H s*, having bearing stud or lug, and the adjustable pattern *I*, substantially as and for the purpose described.

JABEZ C. TERRY.
HERBERT J. TERRY.

Witnesses:

LOVENA H. PEASE,
LOREN H. PEASE.